

# Frigorifero da Incasso Combinato Total No Frost 372 Litri Nuova Classe F Candy

## CBT7719FW

Frigorifero combinato total no frost 193x70 cm, Connettività Wi-Fi con app hOn, Classe Energetica F, Classe climatica ST, Controllo elettronico indipendente Frigo/Freezer, Tecnologia Total No Frost, Volume totale netto 371 litri, Volume totale netto Frigorifero 287 litri, Volume totale netto Congelatore 85 litri, 5 ripiani in vetro trasparente, 2 + 4 balconcini controporta trasparenti, 1 cassetto crisper, Portabottiglie in metallo, Illuminazione SKY LED, Freezer a 3 scomparti con cassetti trasparenti, Sistema antibatterico, Porta reversibile. Annual energy consumption 299, Acoustical noise class B, Rumorosità (dBA) 33, Star Rating 4, Total Freezing Capacity 4,5, Total Capacity Unfrozen, Compartment (l) 281, Total Capacity Frozen, Compartment (l) 83, Total Unit Capacity (l) 364.

Altezza, Larghezza, Profondità del prodotto (mm) 1935X690X545

Altezza, Larghezza, Profondità del prodotto imballato (mm) 1996X730X597

Peso lordo (kg) 73,6 - Peso netto (kg) 72

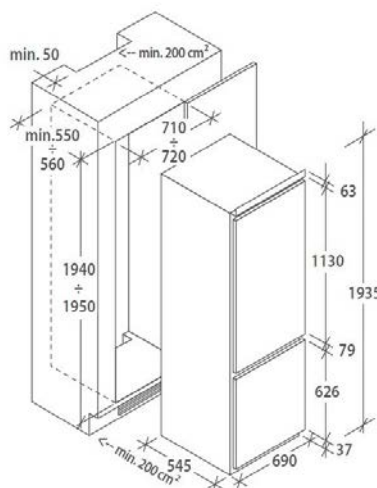

WIFI



CLASSE ENERGETICA



TOTAL NO FROST



TOTAL NO FROST CIRCLE+



SKY LED



CONTROLLO ELETTRONICO



PORTE REVERSIBILI

